

A

B

C

D

E

F

A

B

C

D

E

F

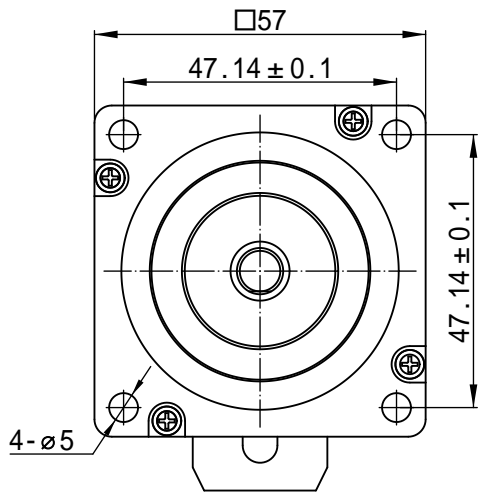
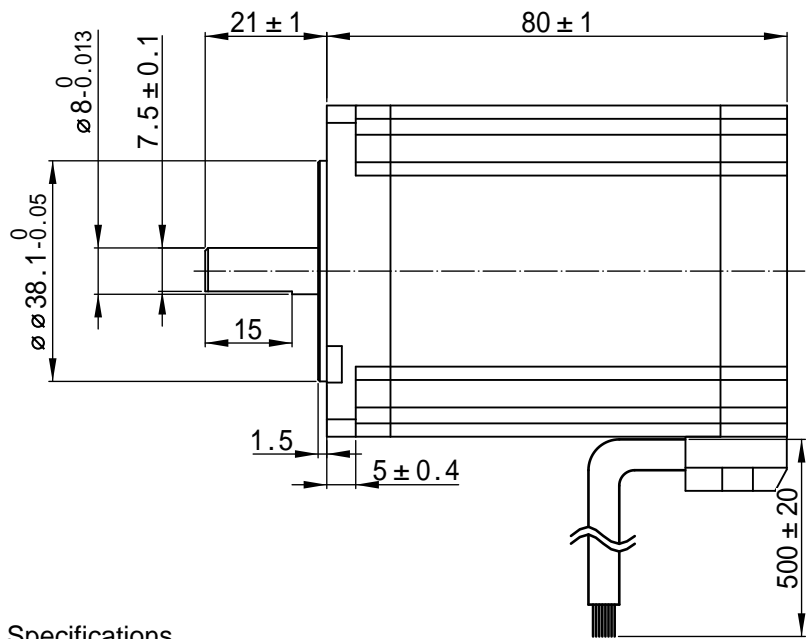

接线图:Wiring Diagram

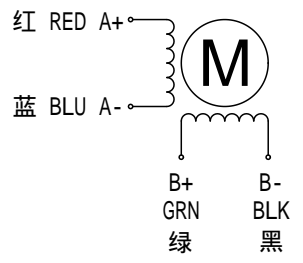

励磁顺序vs.旋转方向  
Exciting Sequence vs. Direction of Rotation

STEP	A+	B+	A-	B-	
1	+	+	-	-	CCW ↑
2	-	+	+	-	
3	-	-	+	+	
4	+	-	-	+	

↓ CW

从安装面看为顺时针方向  
Clockwise view from mouting side

标签 Label Detail



规格 Specifications

1.相数 Number of Phase	2
2.步距角 Step Angle	1.8°
3.额定电压 Rated Voltage	1.9V
4.额定电流 Rated Current	5.0 A
5.保持力矩 Holding Torque	2.4 N.m Typ. ( Two phase on/rated current )
6.相电阻 Phase Resistance	0.38ohm±10% ( 20°C )
7.相电感 Phase Resistance	1.4 mH±20% ( 1kHz 1V rms )
8.转子惯量 Rotor Inertia	0.58kg.cm <sup>2</sup>
9.电机重量 Motor Weight	1.2KG
10.绝缘等级 Insulation Class	B ( 130°C )

单位:毫米 Unit:mm  
第一视角画法  
First angle method

未注线性与角度尺寸公差均按 GB/T 1804-M  
未注形状与位置尺寸公差均按 GB/T 1184-K

批准 Approve		
标准化 Standard		
工艺 Technology	CHEN	2024/07/01
审核 Check	ZHANG	2024/07/01
设计 Design	WANG YI	2024/07/01

锐特技术 RTINTELLIGENT Hybrid Stepping Motor  
ShenZhen Rtelligent Technology Co.LTD  
深圳锐特机电技术有限公司

型号: 57AM24 V3.0

图号:

REV.	版本记录 REVISION RECORD	DATE	UNLESS OTHERWISE SPECIFIED	NAMES	SIGNATURE	DATE	TYPE:	Rev.A	SCALE 1:1	Sheet 1 of 1
------	----------------------	------	----------------------------	-------	-----------	------	-------	-------	-----------	--------------