

A

B

C

D

E

F

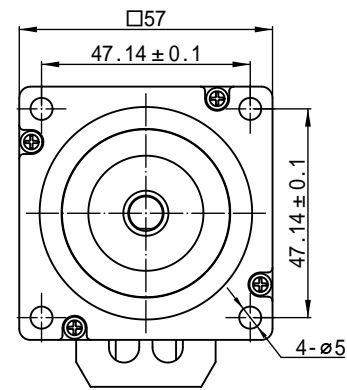
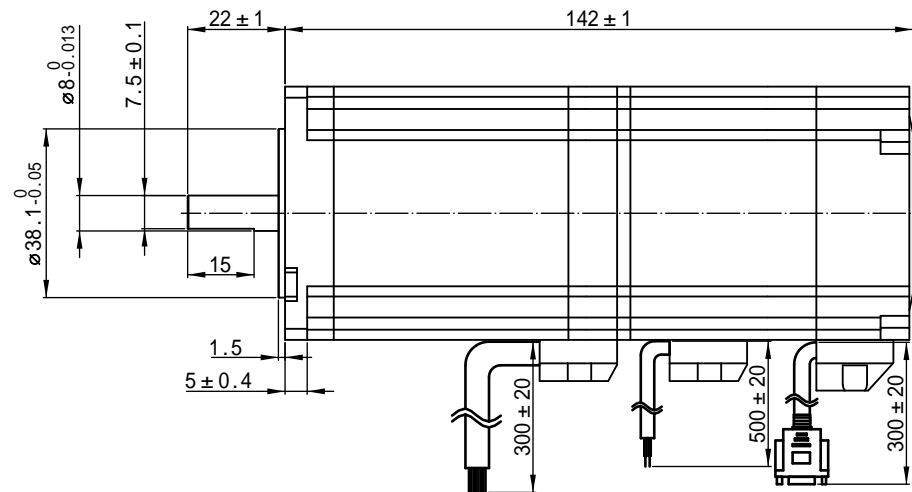

Encoder Signals:

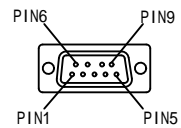

接线图:Wiring Diagram

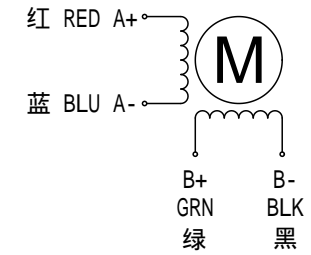

励磁顺序vs.旋转方向
Exciting Sequence vs. Direction of Rotation

STEP	A+	B+	A-	B-	
1	+	+	-	-	CW
2	-	+	+	-	
3	-	-	+	+	
4	+	-	-	+	CW

从安装面看为顺时针方向
Clockwise view from mouting side

标签 Label Detail

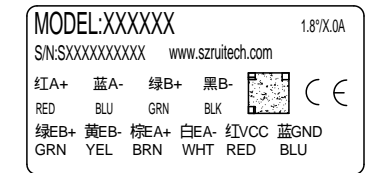

制动器规格 Brake Specification

Voltage	24Vdc
Friction torque	1.8N.M
认证	认证
认证	认证

规格 Specifications

1.相数 Number of Phase	2
2.步距角 Step Angle	1.8°
3.额定电压 Rated Voltage	1.85V
4.额定电流 Rated Current	5.0A
5.保持力矩 Holding Torque	2.3 N.m Typ. (Two phase on/rated current)
6.相电阻 Phase Resistance	0.37ohm±10% (20°C)
7.相电感 Phase Resistance	1.5 mH±20% (1kHz 1V rms)
8.转子惯量 Rotor Inertia	0.48K g.cm^2
9.电机重量 Motor Weight	1.7KG
10.绝缘等级 Insulation Class	B (130°C)

序号	1	2	4	5	8	9
定义	EA+	EA-	EB+	EB-	5V	GND
线色	棕	白	绿	黄	红	蓝

REV.	版本记录 REVISION RECORD	DATE	UNLESS OTHERWISE SPECIFIED	NAMES	SIGNATURE	DATE	TYPE:	Rev.A	SCALE 1:1	Sheet 1 of 1	
			单位:毫米 Unit:mm 第一视角画法 First angle method 未注线性与角度尺寸公差均按 GB/T 1804-M 未注形状与位置尺寸公差均按 GB/T 1184-K	批准 Approve			 Hybrid Stepping Motor ShenZhen Rtelligent Technology Co.LTD 深圳锐特机电技术有限公司				
				标准化 Standard				型号: 57AM24ED-Z2 V3.0			
				工艺 Technology	CHEN	2024/07/01		图号:			
				审核 Check	ZHANG	2024/07/01					
				设计 Design	WANG YI	2024/07/01					