

A

B

C

D

E

F

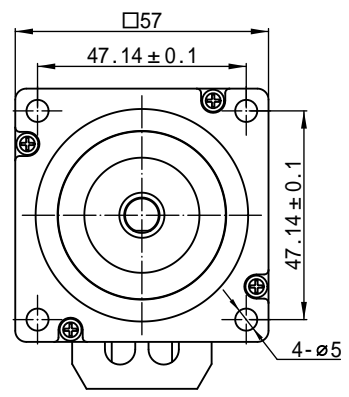
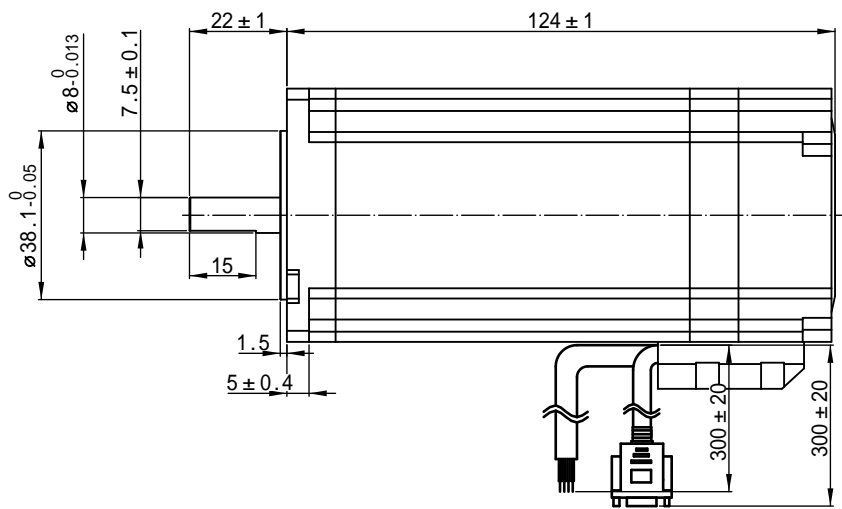

Encoder Signals:

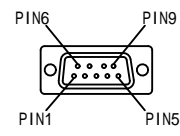

序号	1	2	4	5	8	9
定义	EA+	EA-	EB+	EB-	5V	GND
线色	棕	白	绿	黄	红	蓝

接线图:Wiring Diagram

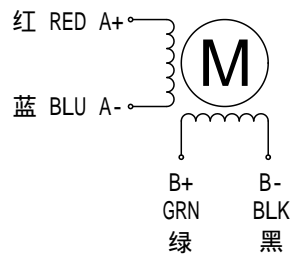

励磁顺序vs.旋转方向
Exciting Sequence vs. Direction of Rotation

STEP	A+	B+	A-	B-	
1	+	+	-	-	CCW ↑
2	-	+	+	-	
3	-	-	+	+	
4	+	-	-	+	

从安装面看为顺时针方向
Clockwise view from mounting side

标签 Label Detail

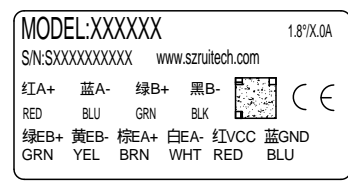

规格 Specifications

1.相数 Number of Phase	2
2.步距角 Step Angle	1.8°
3.额定电压 Rated Voltage	3.3V
4.额定电流 Rated Current	5.0 A
5.保持力矩 Holding Torque	3.0 N.m Typ. (Two phase on/rated current)
6.相电阻 Phase Resistance	0.66ohm±10% (20°C)
7.相电感 Phase Resistance	2.9 mH±20% (1kHz 1V rms)
8.转子惯量 Rotor Inertia	0.7K g.cm^2
9.电机重量 Motor Weight	1.6KG
10.绝缘等级 Insulation Class	B (130°C)

单位:毫米 Unit:mm
第一视角画法
First angle method
未注线性与角度尺寸公差均按 GB/T 1804-M
未注形状与位置尺寸公差均按 GB/T 1184-K

批准 Approve		
标准化 Standard		
工艺 Technology	CHEN	2024/07/01
审核 Check	ZHANG	2024/07/01
设计 Design	WANG YI	2024/07/01

锐特技术
ShenZhen Rtelligent Technology Co.LTD
深圳锐特机电技术有限公司

型号: 57AM30ED V3.0

图号:

REV.	版本记录 REVISION RECORD	DATE	UNLESS OTHERWISE SPECIFIED	NAMES	SIGNATURE	DATE	TYPE:	Rev.A	SCALE 1:1	Sheet 1 of 1
------	----------------------	------	----------------------------	-------	-----------	------	-------	-------	-----------	--------------