

A

B

C

D

E

F

A

B

C

D

E

F

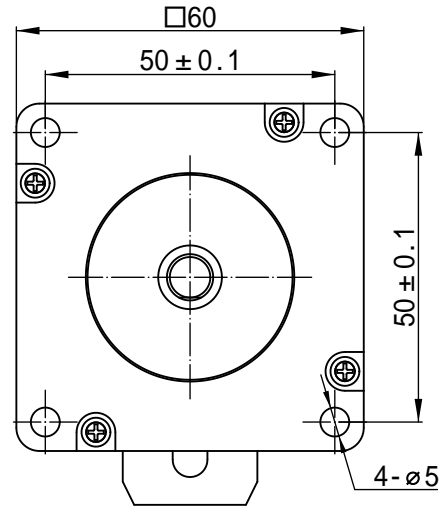
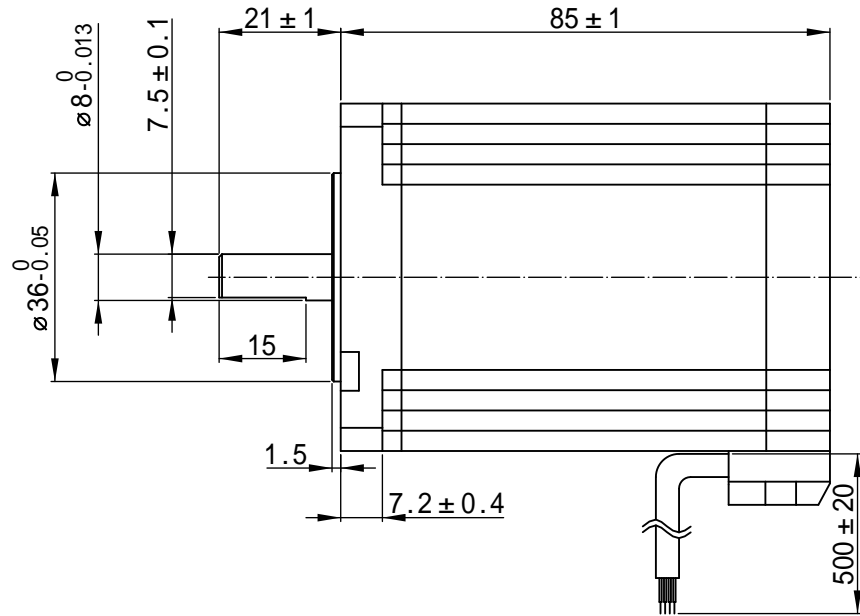

接线图:Wiring Diagram

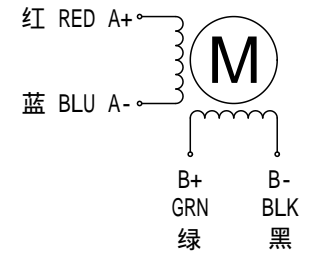

励磁顺序vs.旋转方向
Exciting Sequence vs. Direction of Rotation

STEP	A+	B+	A-	B-	
1	+	+	-	-	CCW ↑
2	-	+	+	-	
3	-	-	+	+	
4	+	-	-	+	

从安装面看为顺时针方向
Clockwise view from mouting side

标签 Label Detail

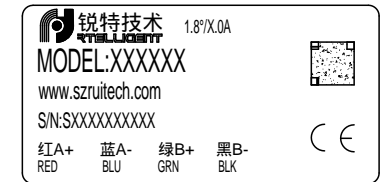

规格 Specifications

1.相数 Number of Phase	2
2.步距角 Step Angle	1.8 °
3.额定电压 Rated Voltage	3.15V
4.额定电流 Rated Current	5.0 A
5.保持力矩 Holding Torque	3.0 N.m Typ. (Two phase on/rated current)
6.相电阻 Phase Resistance	0.63ohm±10% (20°C)
7.相电感 Phase Resistance	2.2 mH±20% (1kHz 1V rms)
8.转子惯量 Rotor Inertia	0.84kg.cm ²
9.电机重量 Motor Weight	1.42KG
10.绝缘等级 Insulation Class	B (130°C)

单位:毫米 Unit:mm

第一视角画法
First angle method

未注线性与角度尺寸公差均按
GB/T 1804-M

未注形状与位置尺寸公差均按
GB/T 1184-K



批准 Approve

标准化 Standard

工艺 Technology

审核 Check

设计 Design

CHEN

ZHANG

WANG YI

2024/07/01

2024/07/01

2024/07/01

2024/07/01

2024/07/01

2024/07/01

2024/07/01



Hybrid Stepping Motor

ShenZhen Rtelligent Technology Co.LTD
深圳锐特机电技术有限公司

型号: 60AM30 V3.0

图号: