

A

B

C

D

E

F

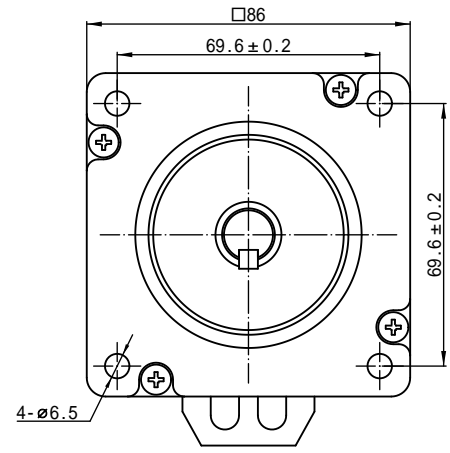
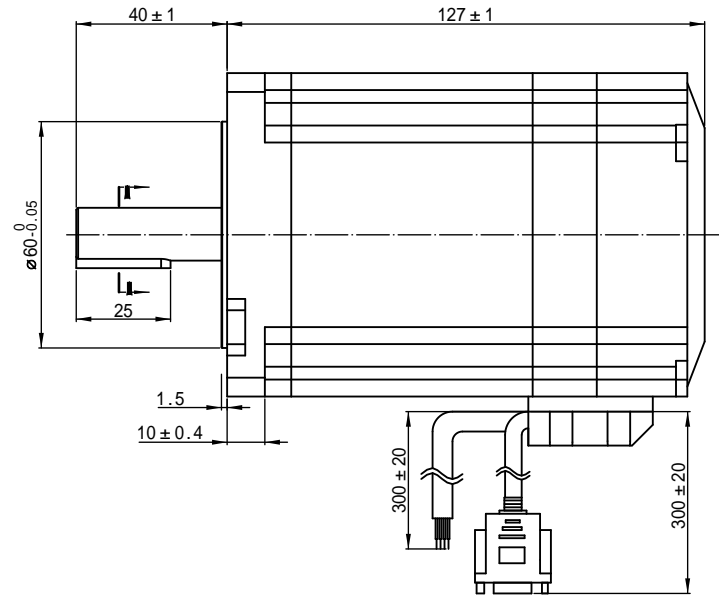
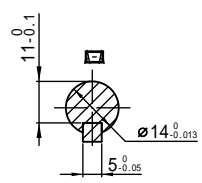

Encoder Signals:

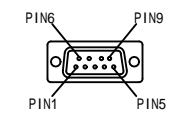

序号	1	2	4	5	8	9
定义	EA+	EA-	EB+	EB-	5V	GND
线色	棕	白	绿	黄	红	蓝

接线图:Wiring Diagram

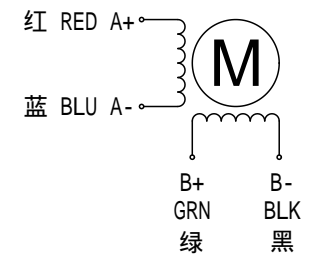

励磁顺序vs.旋转方向  
Exciting Sequence vs. Direction of Rotation

STEP	A+	B+	A-	B-	
1	+	+	-	-	CW
2	-	+	+	-	
3	-	-	+	+	
4	+	-	-	+	CCW

从安装面看为顺时针方向  
Clockwise view from mounting side

标签 Label Detail

MODEL:XXXXXX 1.8°/X.0A

S/N:XXXXXXXXXX www.szruiotech.com

红A+ 蓝A- 绿B+ 黑B-

RED BLU GRN BLK

绿EB+ 黄EB- 棕EA+ 白EA- 红VCC 蓝GND

GRN YEL BRN WHT RED BLU

规格 Specifications

1.相数 Number of Phase	2
2.步距角 Step Angle	1.8 °
3.额定电压 Rated Voltage	3.6V
4.额定电流 Rated Current	6.0A
5.保持力矩 Holding Torque	6.5 N.m Typ. ( Two phase on/rated current )
6.相电阻 Phase Resistance	0.60hm±10% ( 20°C )
7.相电感 Phase Resistance	4.2mH±20% ( 1kHz 1V rms )
8.转子惯量 Rotor Inertia	2.8 Kg.cm^2
9.电机重量 Motor Weight	3.2KG
10.绝缘等级 Insulation Class	B ( 130°C )

F	单位:毫米 Unit:mm	批准 Approve	Hybrid Stepping Motor ShenZhen Rtelligent Technology Co.LTD 深圳锐特机电技术有限公司							
	第一视角画法 First angle method	标准化 Standard								
	未注线性与角度尺寸公差均按 GB/T 1804-M	工艺 Technology	CHEN	2024/07/01						
	未注形状与位置尺寸公差均按 GB/T 1184-K	审核 Check	ZHANG	2024/07/01						
原始版本 Original revision	设计 Design	WANG YI	2024/07/01	型号: 86AM65ED V3.0						
REV.	版本记录 REVISION RECORD	DATE	UNLESS OTHERWISE SPECIFIED	NAMES	SIGNATURE	DATE	TYPE:	Rev.A	SCALE 1:1	Sheet 1 of 1