

永磁交流伺服电动机规格书

PERMANENT MAGNET AC SERVO MOTOR SPECIFICATION

版本 REV	变更号 ECN NO	变更内容 CONTENT CHANGED	处数 NO.	日期 DATE	设计 DESIGN

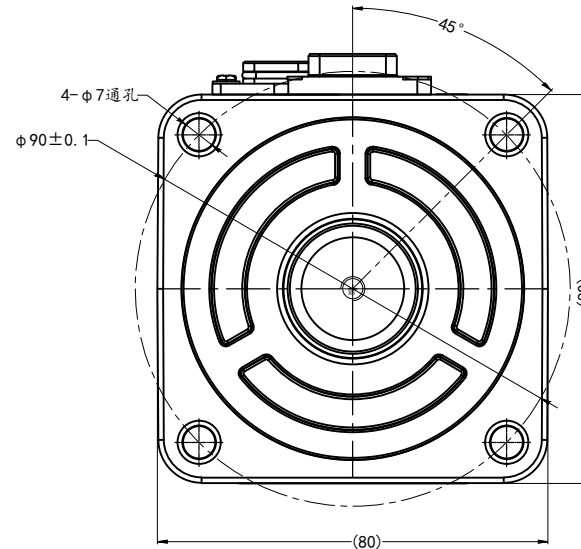
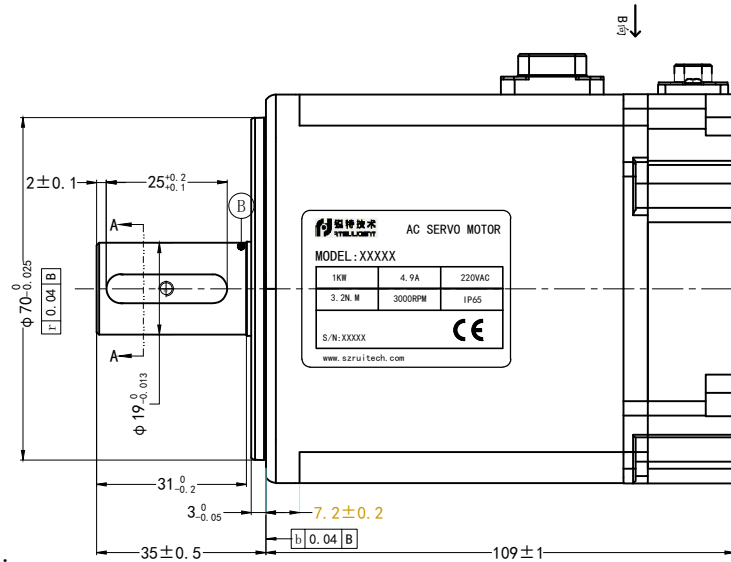

使用说明:

Instructions

使用环境温度-20--55° C不结冰

Operating ambient temperature -20--55 ° C no ice

使用环境温度20%--80%RH不结露

Operating environment humidity 20%--80%rh no condensation

1000m以下使用, 1000m以上请降额使用, 具体参照海拔降额曲线

For use below 1000m, please reduce the rating for use above 1000m.

Refer to the altitude derating curve for details

参数列表

parameters List

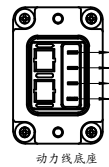
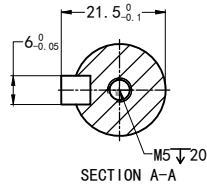

B向视图



编码器线底座

型号 Model	编码器 encoder
RSDA-H08J3230C V3.1	17位单圈磁编 17 bit single coil magnetic encoder
RSDA-H08G3230C V3.1	17位多圈磁编 17 bit multi coil magnetic encoder
RSDA-H08L3230C V3.1	23位多圈光电 23 bit multi turn photoelectric

额定电压 Rated Voltage (V)	220	线电阻 Line-Line Resistance (Ω)	1.5 ± 10% (20°C)
额定功率 Rated Power (W)	1000	线电感 Line-Line Inductance (mH)	5.5 ± 20% (20°C)
额定电流 Rated Current (A)	4.9	转动惯量 Rotor inertia (× 10 ⁻⁴ kg·m ²)	1.9
峰值电流 Peak Current (A)	14.7	绝缘等级 Insulation Class	F
额定转速 Rated Speed (rpm)	3000	绝缘电阻 Insulation resistance	DC1000V ≥ 20MΩ
最高转速 Peak Speed (rpm)	6000	防护等级 Protection class	IP65
额定转矩 Rated Torque (N.M)	3.2	允许最大径向负载 Maximum allowable radial load (N)	390
峰值扭矩 Peak Torque (N.M)	9.6	允许最大轴向负载 Maximum allowable axial load (N)	140
反电势 Voltage Constant (V/Krpm)	44.7	重量 Weight (kg)	
力矩系数 Torque Coefficient (N.M/A)	0.65		

编码器接线顺序 (其中5、6号为多圈和光电编码器用) magnetic encoder wiring sequence (numbers 5 and 6 are used for multi turn and photoelectric encoders)							
序号 Serial number	1	2	3	4	5	6	7
颜色 Color	屏蔽	白 White	黑 Black	蓝 Blue	紫 Purple	红 Red	黄 Yellow
定义 Definition	PE	VCC	GND	SD+	SD-	BAT+	BAT-

电机绕组接线顺序 Motor winding wiring sequence				
序号 Serial number	1	2	3	4
颜色 Color	红 Red	白 White	黑 Black	黄绿 Yellow/Green
定义 Definition	U	V	W	PE

CTQ SIGN: Customer Process Law
材料符合ROHS要求 All Material Are To Be Rohs Compliant

锐特技术 深圳锐特机电技术有限公司
RTelligent Shenzhen Rteligent Technology Co., Ltd

NAMES	SIGNATURE	DATE	Unspecified tolerance
设计 DESIGN			常规公差: Tolerances 角度 Angles ± 0.1° 倒角 Chamfer ± 0.3
标准化 STANDARD			Unit:mm GB/T1804-M ISO2768-1 ClassM
审核 CHECK			

视角 FIRST ANGLE METHOD	比例 SCALE	单位 UNIT	变更标识 ECN SIGN	名称 TITLE
	1:1	mm	*	图号 DWG. NO
件号 PART NUMBER	1	版本 REV	A	表单编号 Form Code